

# Model EC60 - External Double Halyard

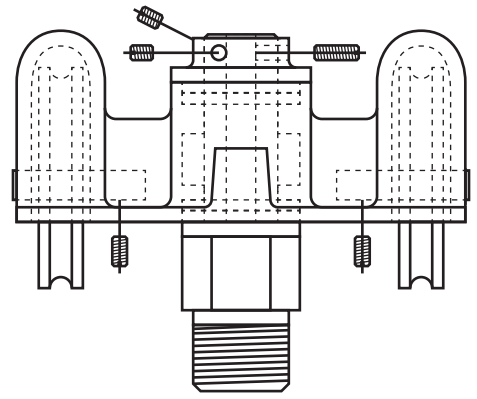
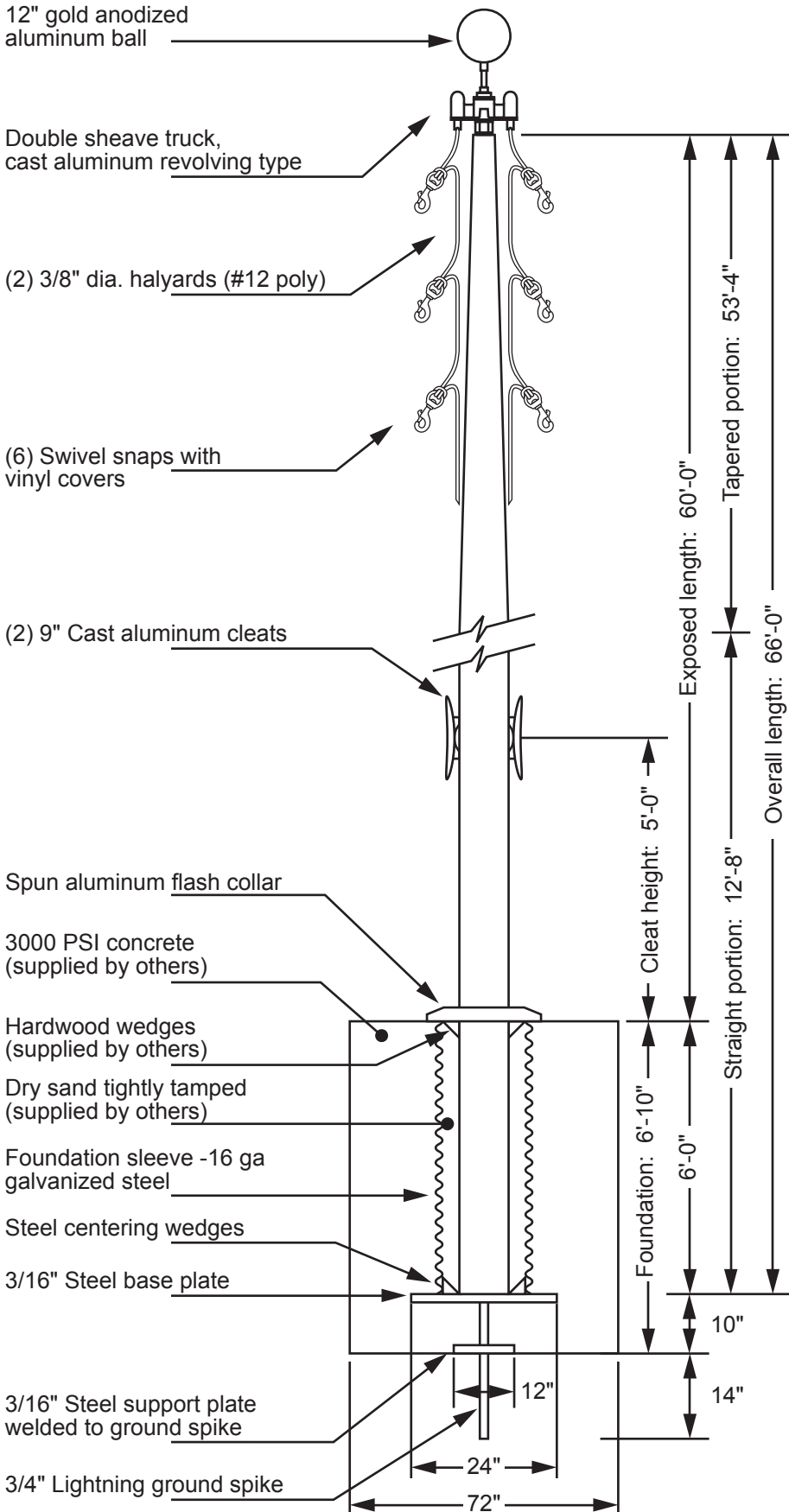

**Double Sheave Truck Detail**  
 Revolving truck  
 Cast aluminum body  
 Stainless steel ball bearings  
 Cast aluminum sheaves  
 Cast aluminum spindle

All shafts with overall length of more than 38'-6" are shipped in multiple sections.

Each section is matched and marked for field assembly. Exposed portion of jam sleeve must be **well lubricated** prior to assembly.

1-1/2" maximum gap allowed for field fitting.

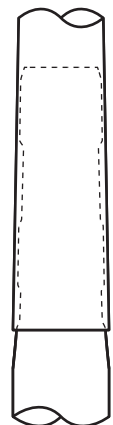

Project:  
 Location:  
 Contractor:  
 Customer:

Date:  
 Job:  
 Revision:

Exposed Height \_\_ 60'-0"  
 Overall Height \_\_ 66'-0"  
 Butt Diameter \_\_ 12"  
 Top Diameter \_\_ 4"  
 Wall Thickness \_\_ .250"  
 Ships in 3 sections

Ground Set Tapered Aluminum Flagpole  
 ALLOY 6063T6  
 80 grit polish  
 FINISH:

**EDER FLAG**  
 1000 W. Rawson Avenue  
 Oak Creek, WI 53154  
 www.ederflag.com

